

APPLICATION:

PRODUCT NAME:
SINGLE DECK DUAL CONTROL VALVE

JOB NAME:

SPECIAL CONFIGURATION
 CHECK BASE MODEL AND OPTIONS

QUANTITY:

ITEM NO.

MODEL:
 10529

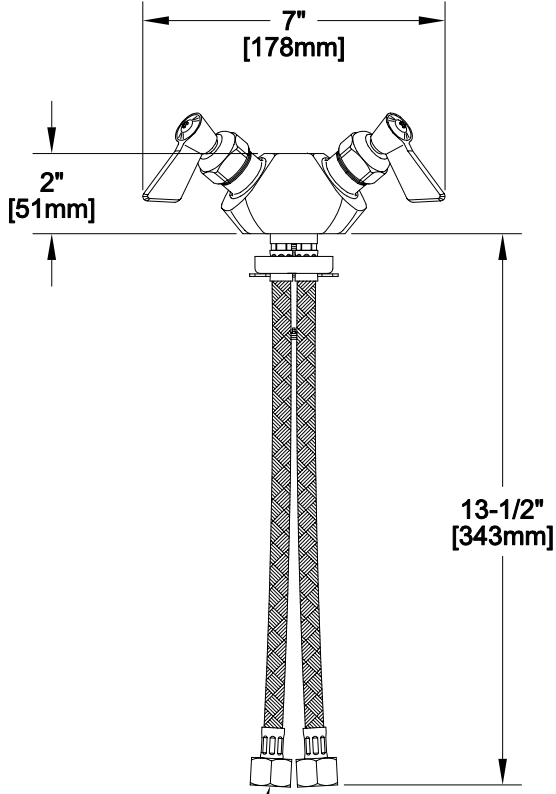

OPTIONS OR MODIFICATIONS:
 SUPPLY LINES (24" OR 36") CIRCLE LENGTH
 HANDLES (CROSS OR WRIST) CIRCLE STYLE
 VANDAL RESISTANT KIT
 OTHER _____

FEATURES

- CONTROL VALVE**
- * 3/8" FEMALE NPT OUTLET
 - * HOT SIDE STEM - RIGHT HAND
 - * COLD SIDE STEM - LEFT HAND
 - * SWIVELLING SEAT DISKS
 - * STAINLESS STEEL SEATS
 - * STAINLESS STEEL SEAT SCREWS
 - * STAINLESS STEEL HANDLE SCREWS
 - * FLEXIBLE INLET HOSES

- SYSTEM LIMITS**
- * TEMP: 40°F MIN. TO 140°F MAX.
 - * PRESSURE: 200 PSI MAX. STATIC

- SHIPPING WEIGHT**
- * 5.0 LBS

1/2" NPT FEMALE

ROUGH-IN:

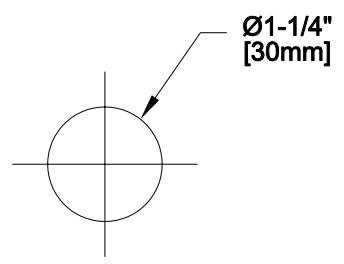

FISHER

FISHER MANUFACTURING COMPANY
 TOLL FREE: 800-421-6162 - FAX: 800-832-8238
 information@fisher-mfg.com - www.fisher-mfg.com